

YONI MEJA RIAS



60 Menit



2 Orang

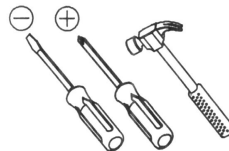

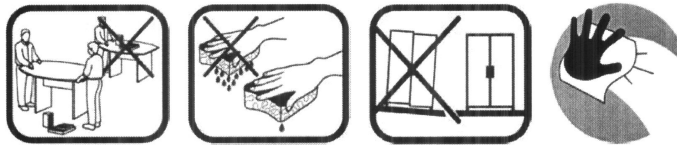
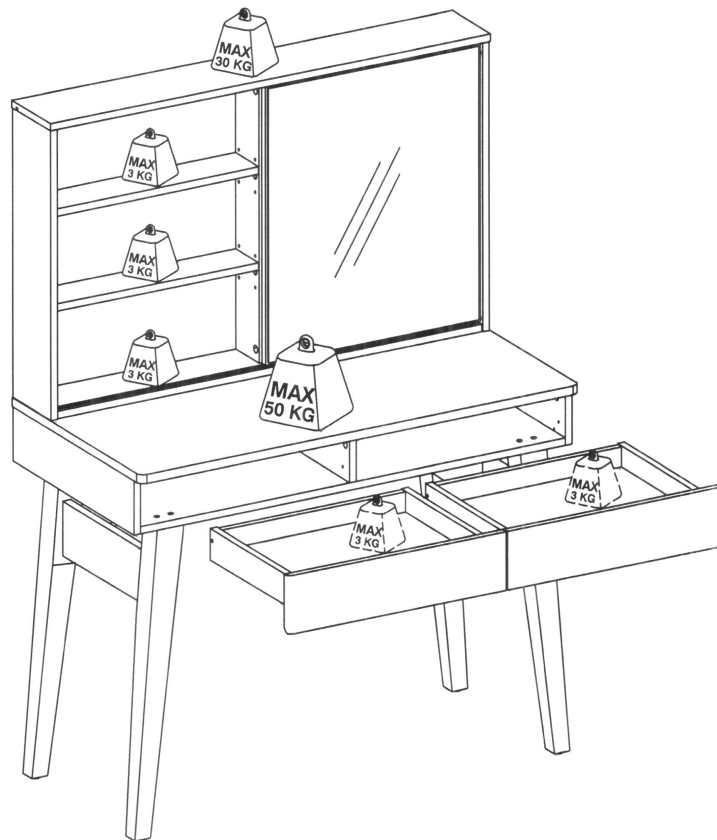

1. Beban pada ilustrasi di bagian **INFORMASI PRODUK** adalah beban dalam keadaan diam dengan distribusi merata pada semua permukaan.
2. Pindahkan produk ini dengan cara mengangkat, jangan didorong karena dapat merusak bagian kaki.
3. Bila terkena cairan, langsung bersihkan dengan menggunakan kain yang lembut.
4. Jangan meletakkan benda-benda bersuhu tinggi tanpa menggunakan alas.
5. Permukaan produk tidak boleh terkena cairan kimia. contoh : thinner, cat kuku.
6. Membersihkan produk cukup dengan kain kering, namun bila diperlukan dapat menggunakan kain lembab bukan basah.
7. Jangan memanjat atau bergelantungan di laci, pintu atau rak.
8. Laminasi permukaan menggunakan material dasar Kertas.
9. Kaca bukan merupakan *tempered glass*, hindari meletakkan benda terlalu kencang.
10. Jangan meletakkan benda panas langsung diatas permukaan. Selalu gunakan tatakan penahan panas. Terdapat resiko permukaan bergelembung akibat kontak fisik dengan benda panas akibat penguapan lapisan adesif antara papan kayu dengan lapisan laminasi.
11. Jangan meletakkan benda basah langsung diatas permukaan. Selalu gunakan tatakan agar permukaan tidak terkena cairan. Terdapat resiko permukaan berubah warna dan lapisan menjadi lapuk akibat kontak fisik dengan benda basah.

PART LIST

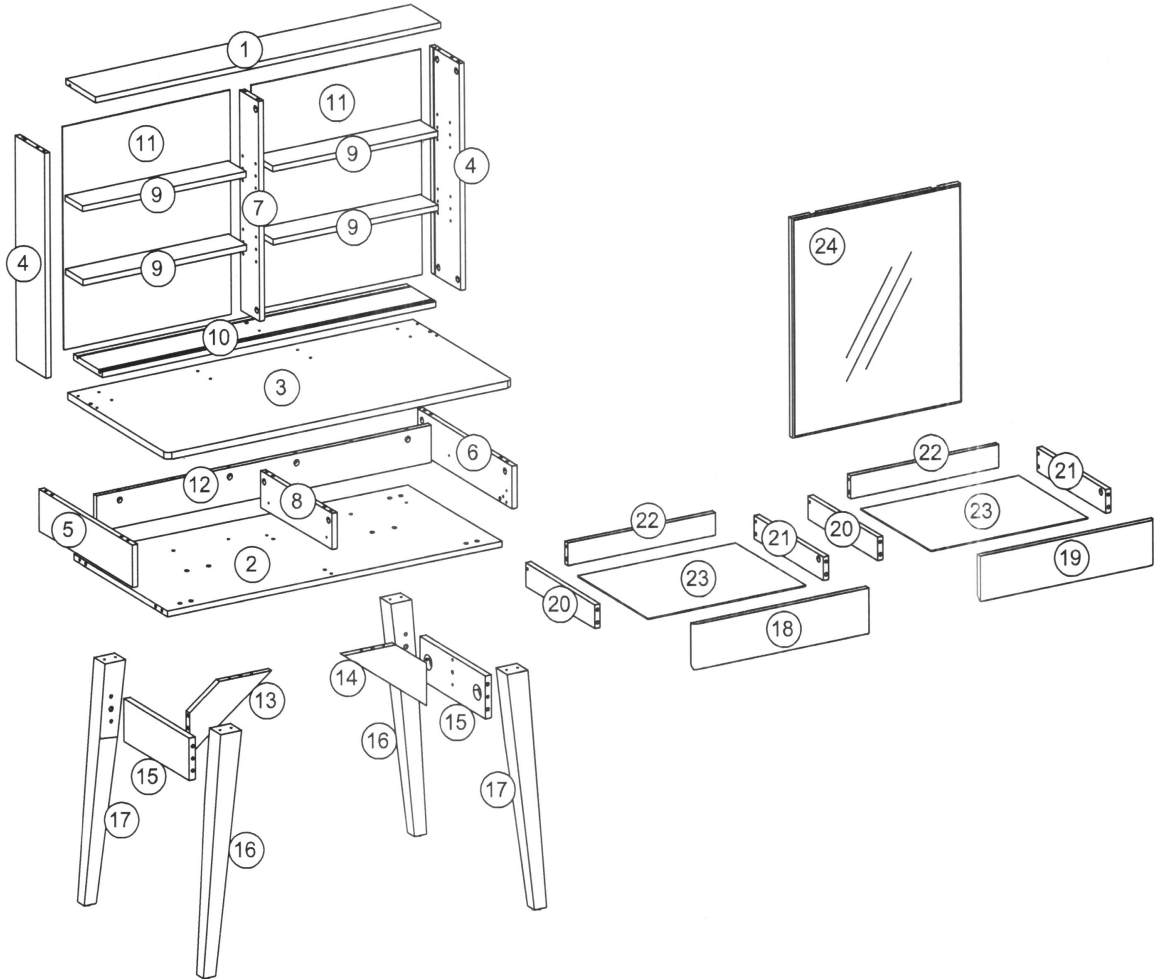

No.	Size	Qty
1	1000 x 150 x 15 mm	1
2	967 x 472 x 15 mm	1
3	1000 x 500 x 18 mm	1
4	585 x 148 x 15 mm	2
5	105 x 472 x 15 mm	1
6	105 x 472 x 15 mm	1
7	570 x 92 x 15 mm	1
8	355 x 90 x 15 mm	1
9	475 x 90 x 15 mm	4
10	965 x 146 x 15 mm	1
11	581 x 489 x 2.5 mm	2
12	967 x 90 x 15 mm	1

No.	Size	Qty
13	294 x 88 x 18 mm	1
14	294 x 88 x 18 mm	1
15	327 x 110 x 18 mm	2
16	635 x 60 x 55 mm	2
17	635 x 60 x 55 mm	2
18	498 x 115 x 15 mm	1
19	498 x 115 x 15 mm	1
20	340 x 60 x 15 mm	2
21	340 x 60 x 15 mm	2
22	421 x 58 x 15 mm	2
23	450 x 345 x 2.5 mm	2
24	564 x 490 x 18 mm	1

HARDWARE LIST

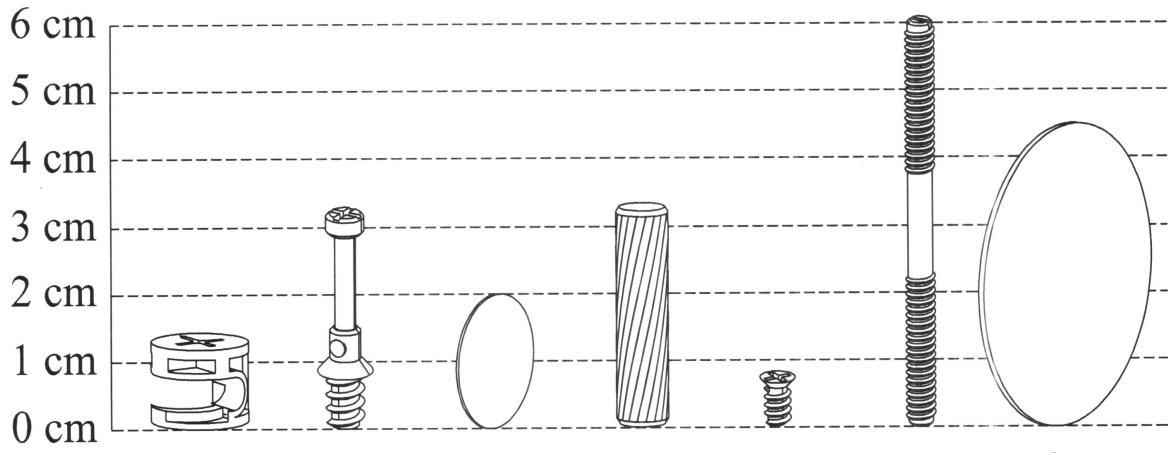

32x DIA. 15 MM A	32x 7.5 X 32 MM B	4x DIA. 20 MM C (WHITE)	42x 8 X 32 MM D	8x 6 X 8 MM E	4x 6 X 60 MM F	4x DIA. 45 MM G
--------------------------------------	---------------------------------------	--	-------------------------------------	-----------------------------------	------------------------------------	-------------------------------------

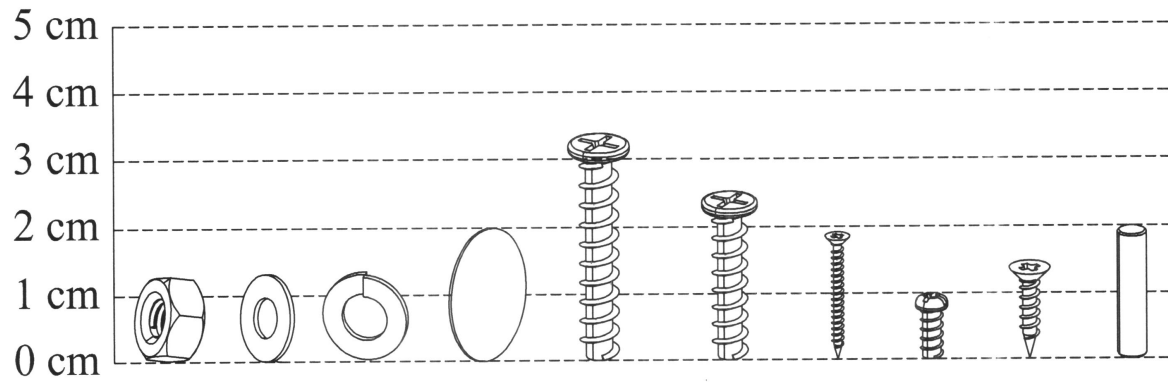

4x M6 H	4x 6 X 13 MM I	4x 6 X 13 MM J	28x DIA. 20 MM K (RIVIERA)	22x 10 X 33.5 MM L	8x 10 X 25 MM M	14x 4 X 19 MM N	8x 4 X 10 MM O	8x 6 X 15 MM P	4x 5 X 20 MM Q
-----------------------------	------------------------------------	------------------------------------	---	--	-------------------------------------	-------------------------------------	------------------------------------	------------------------------------	------------------------------------

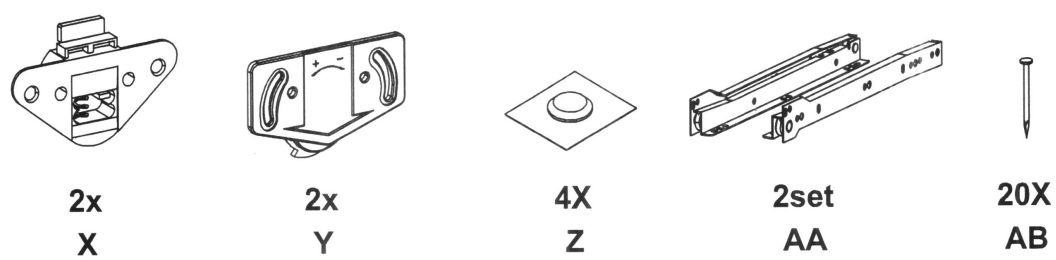
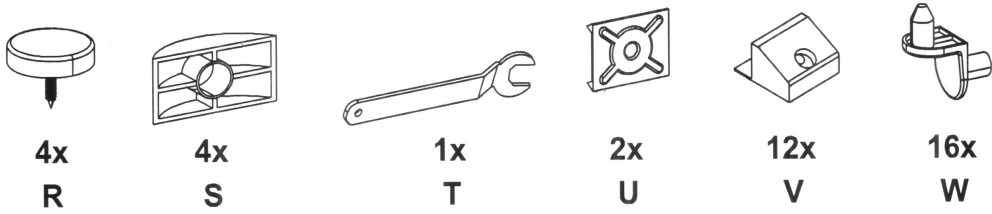

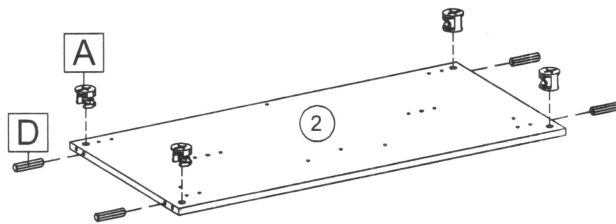
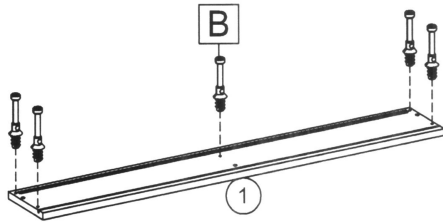
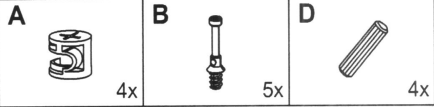
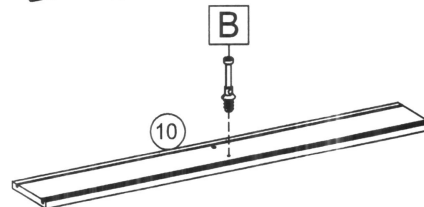
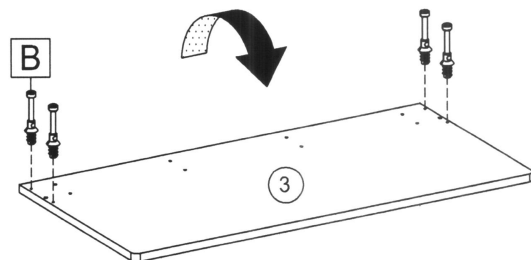
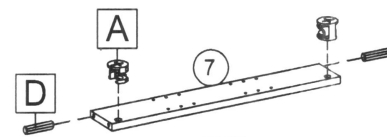
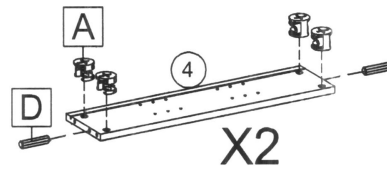
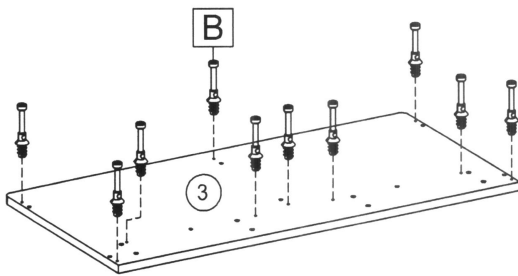
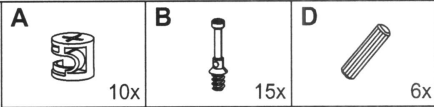
1**2**

3

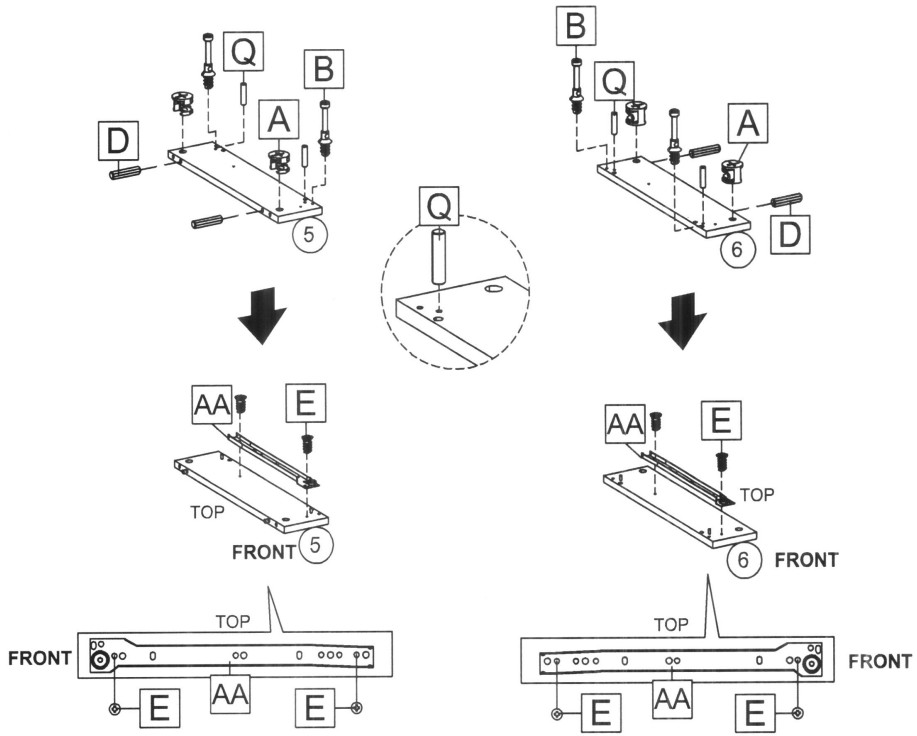
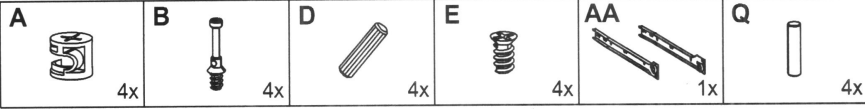

4

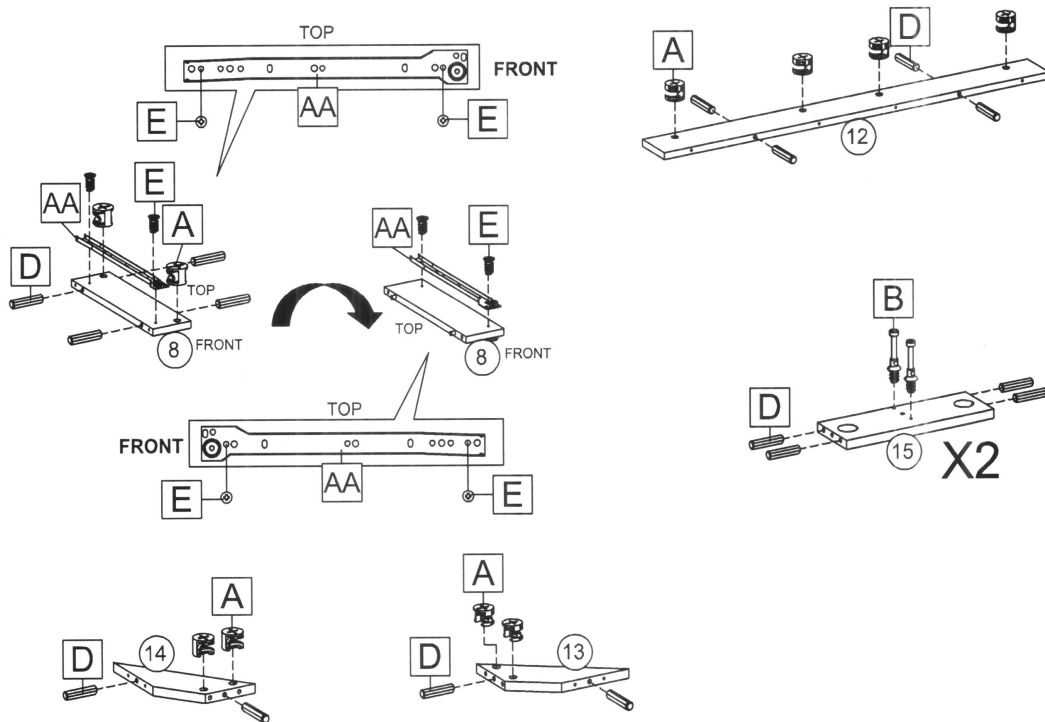
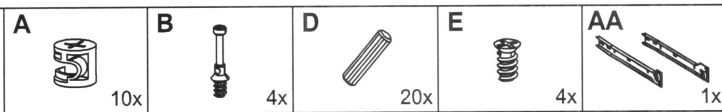

5

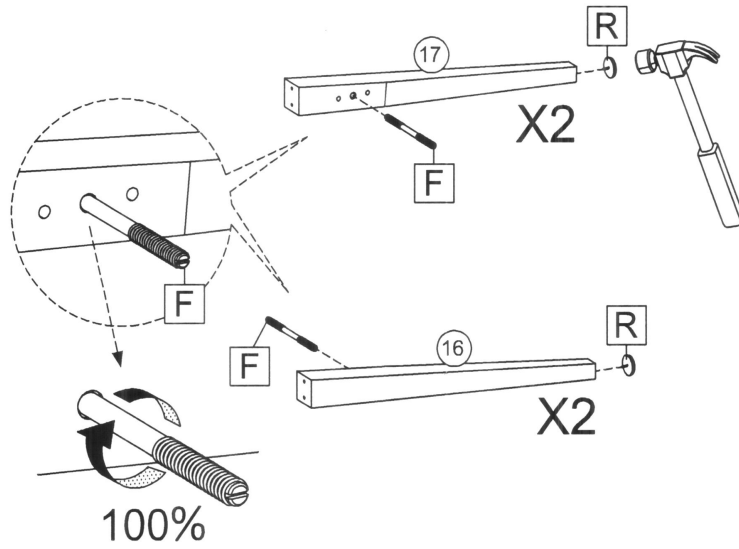
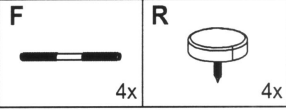

6

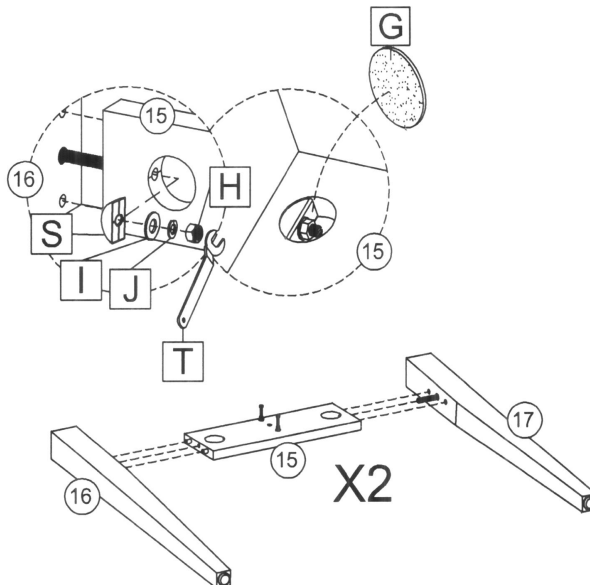

7

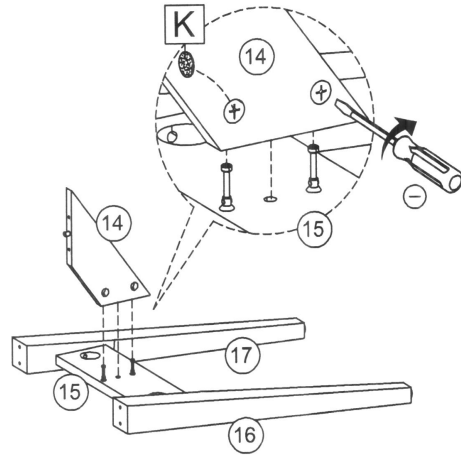
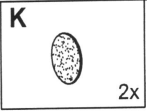

8

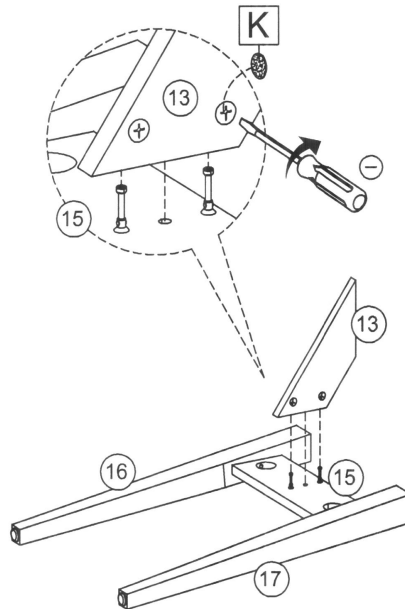
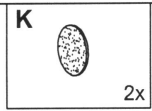

9

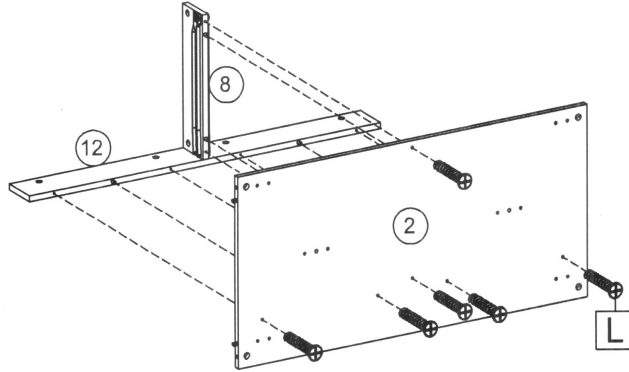
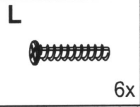

Pastikan memakai
Hardware L
(10 x 33.5 mm)

10

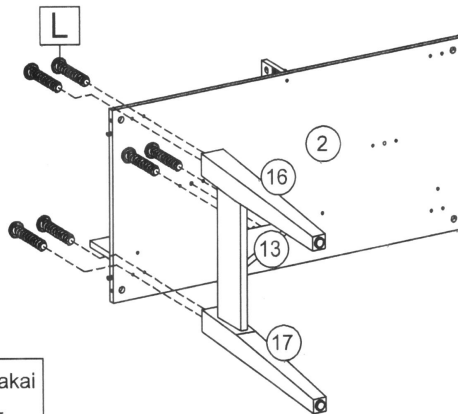
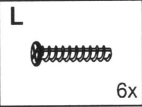

Pastikan memakai
Hardware L
(10 x 33.5 mm)

11

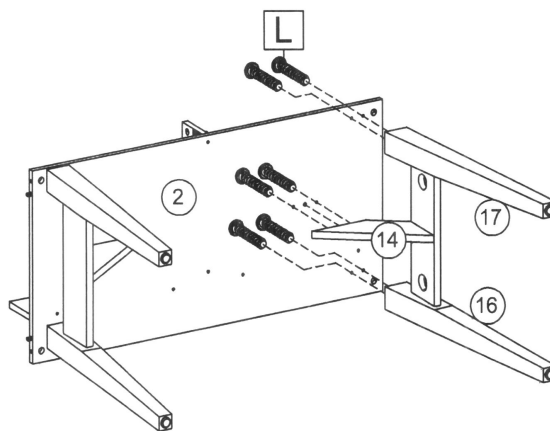
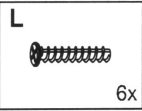

Pastikan memakai
Hardware L
(10 x 33.5 mm)

12

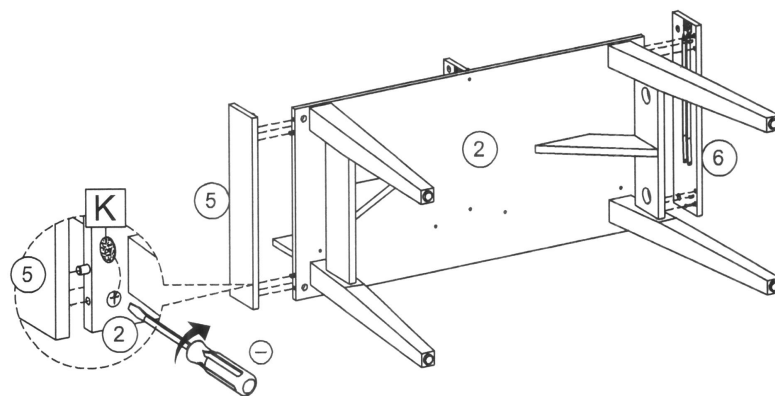
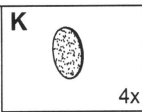

13

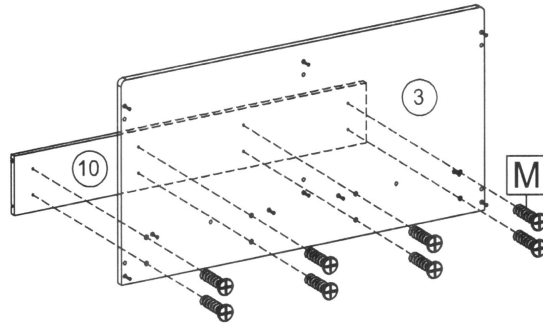
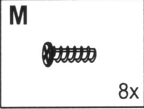

Pastikan memakai
Hardware M
(10 x 25 mm)

14

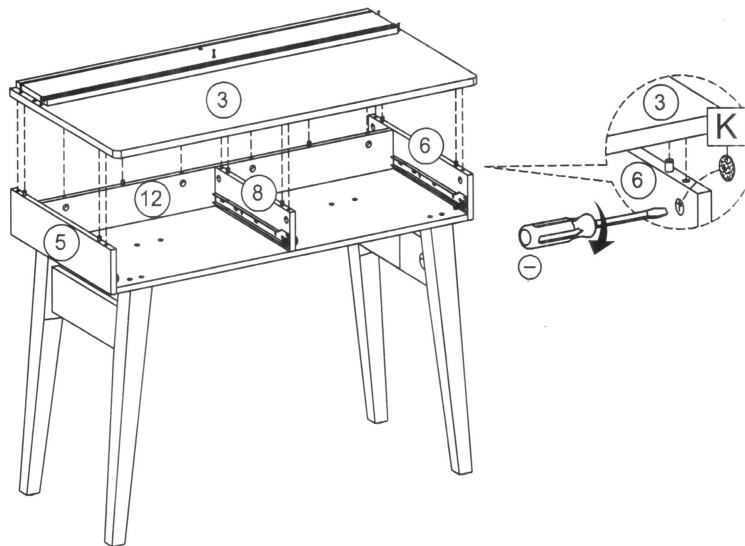
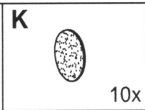

15

K



5x

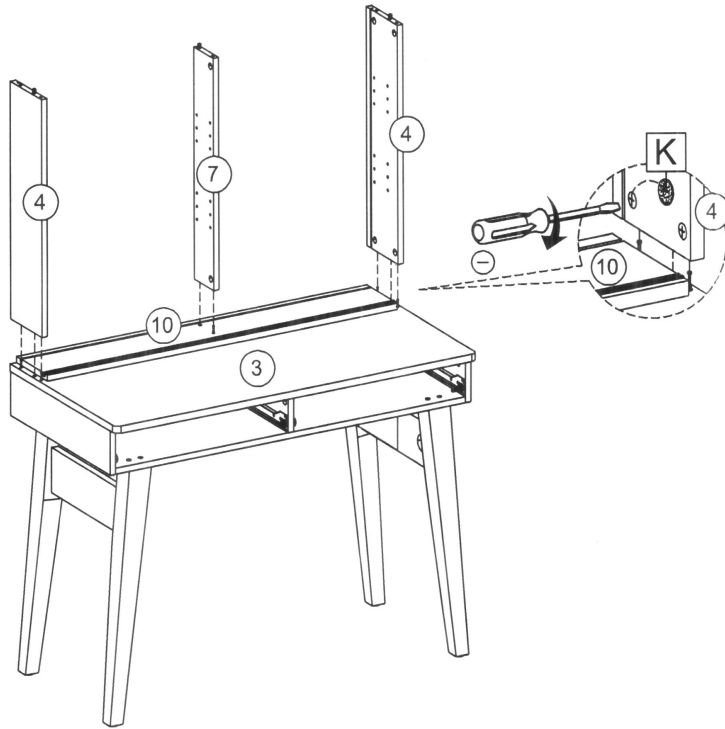

16

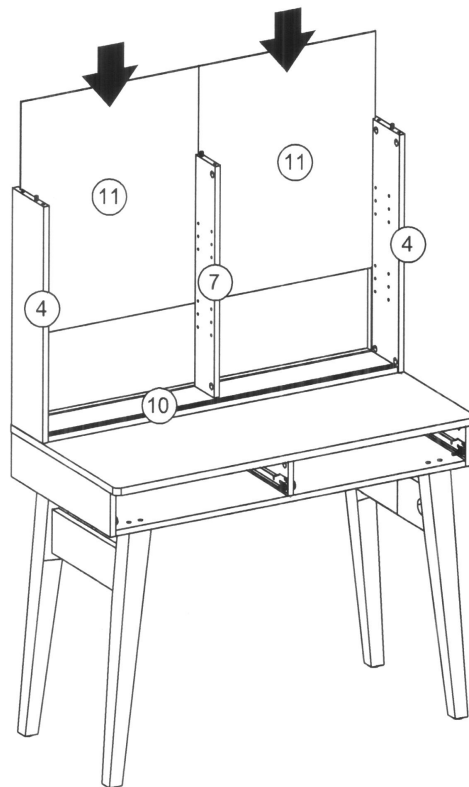

17

K

5x

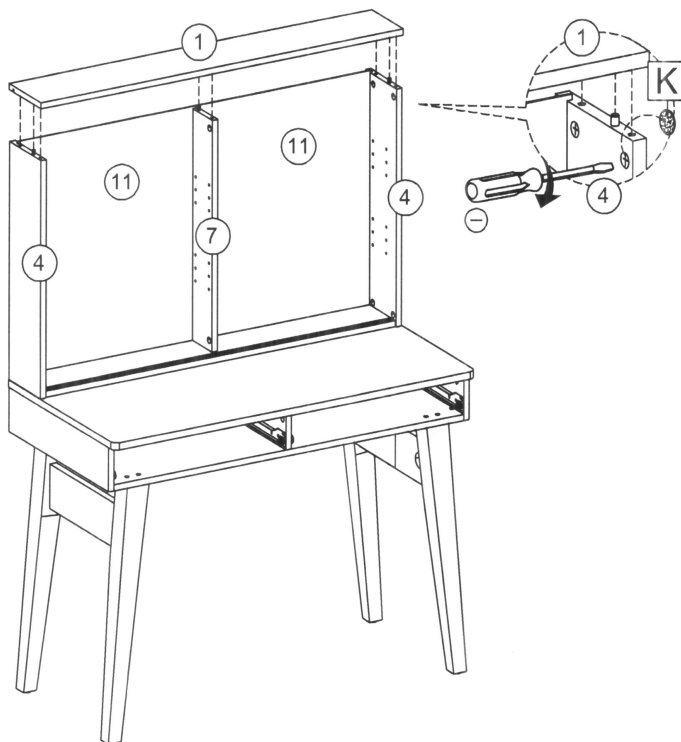

18

U

2x

N

14x

V

12x

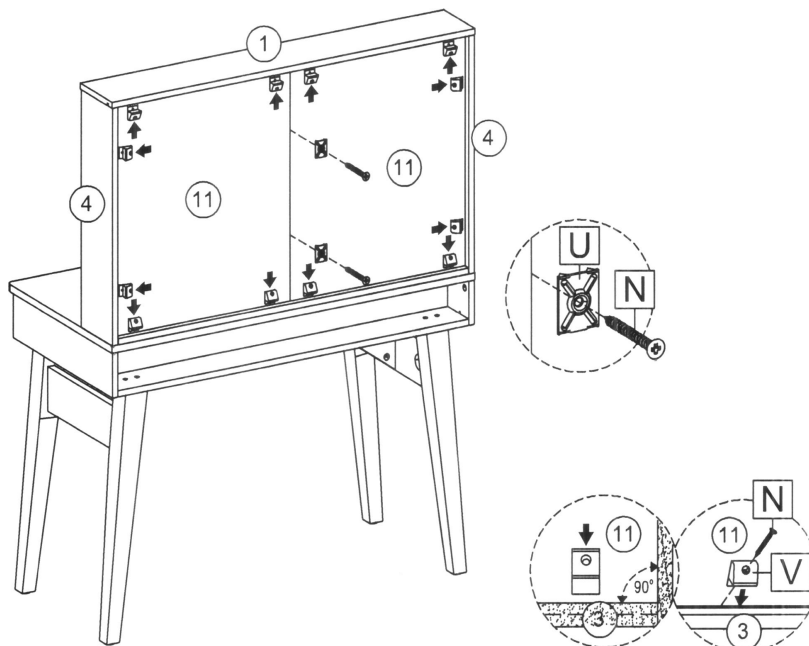

19

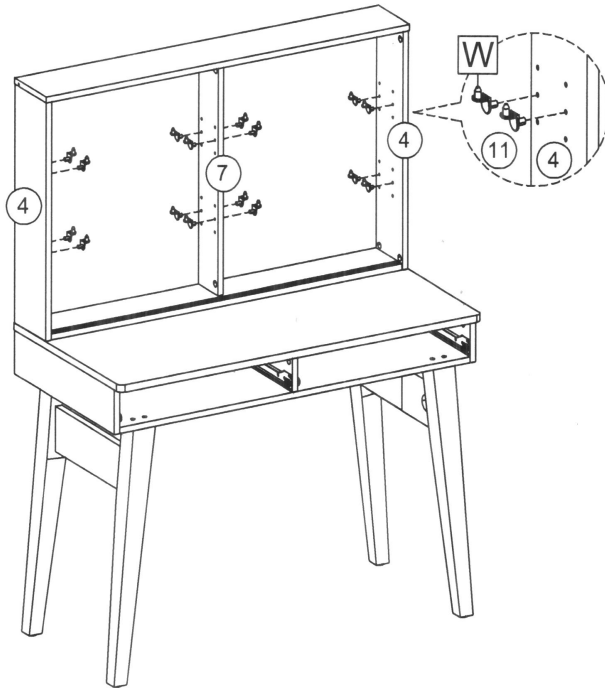
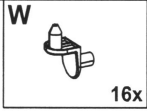

20

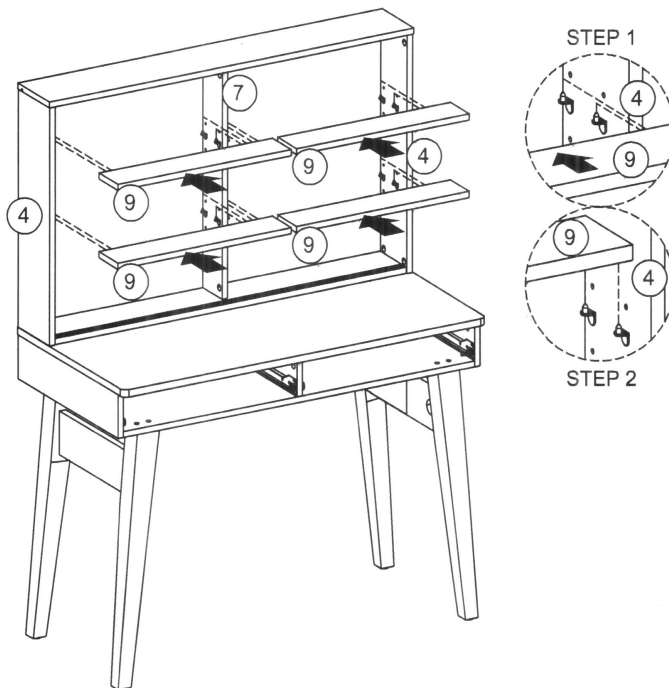

21

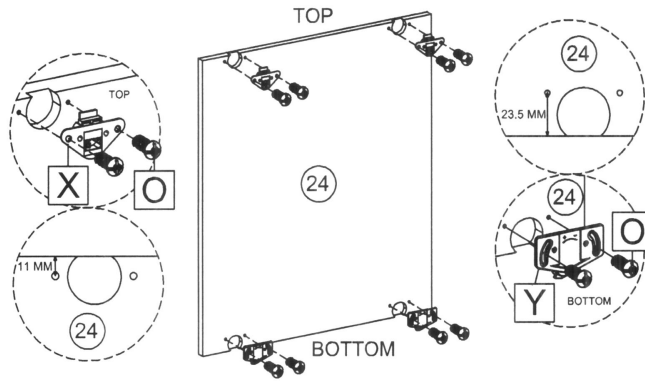
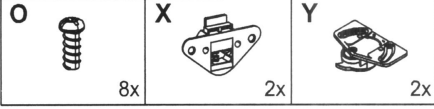

22

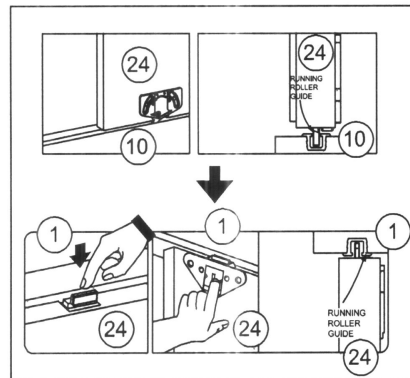
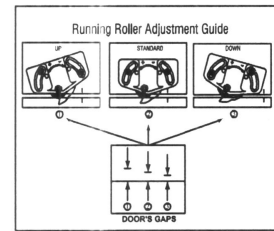
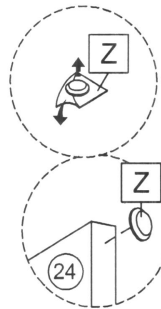
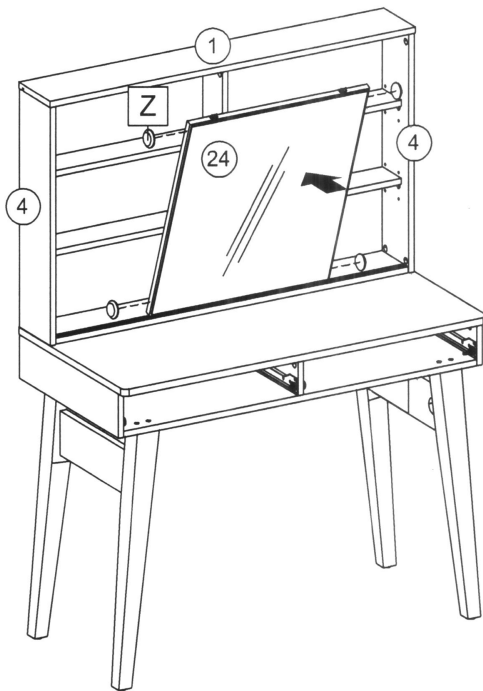
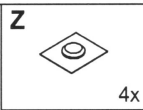

23

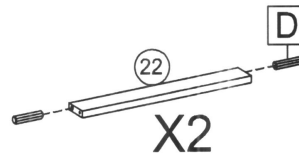
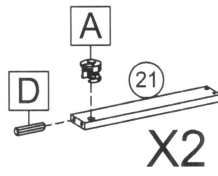
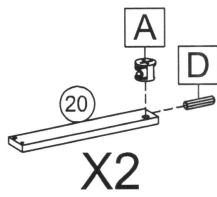
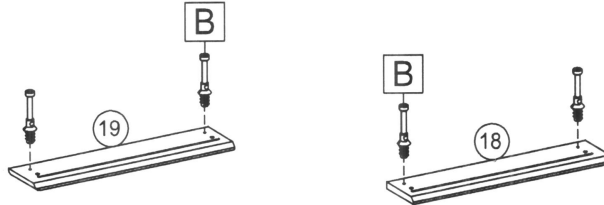
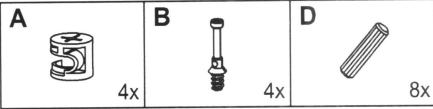

24

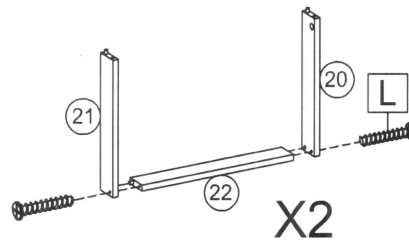
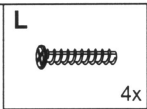

Pastikan memakai
Hardware L
(10 x 33.5 mm)

25

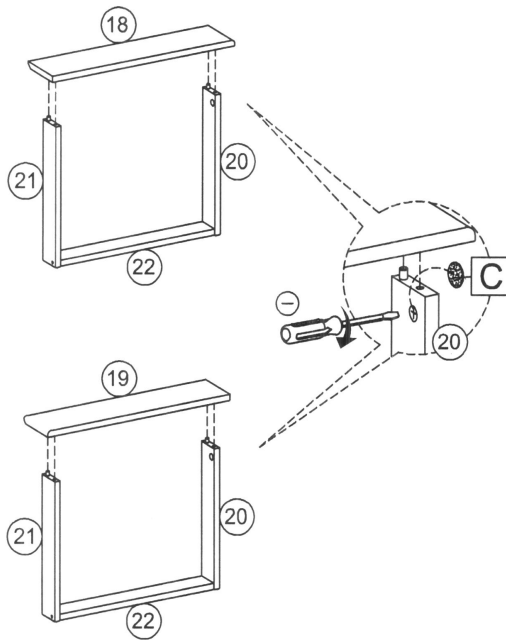
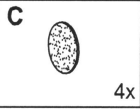

26

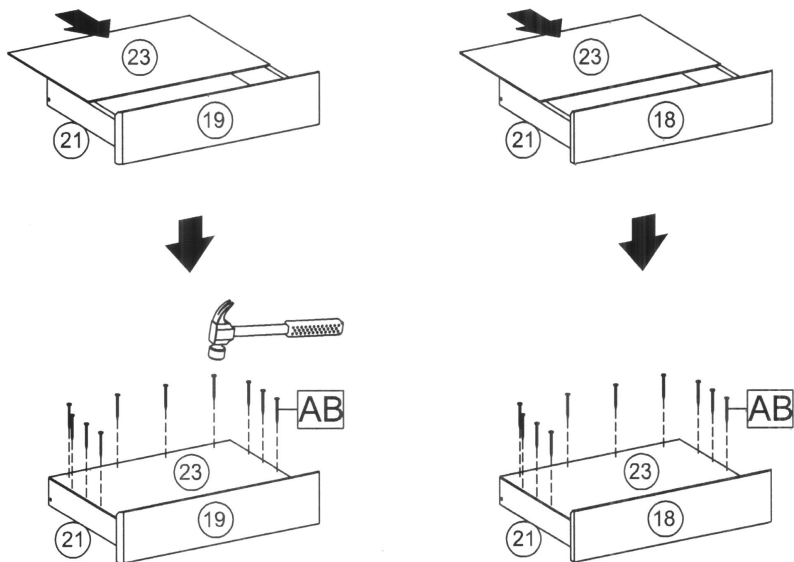
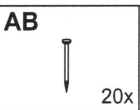

27

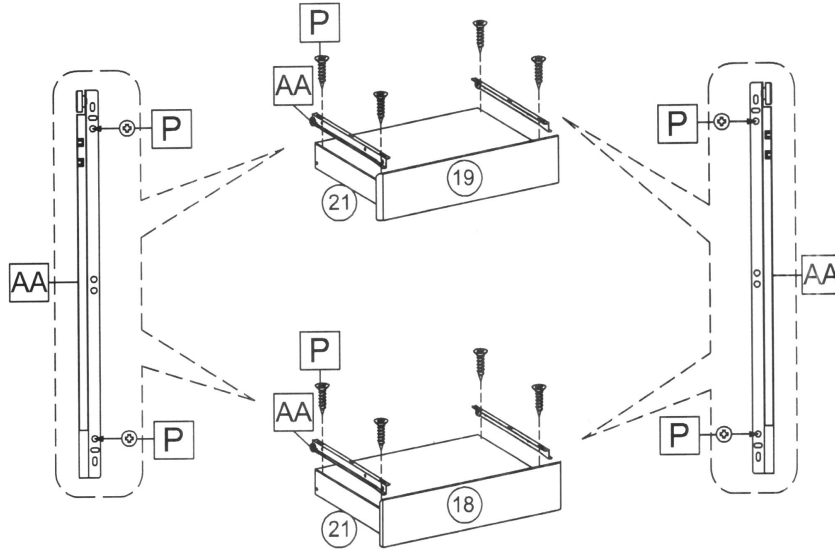
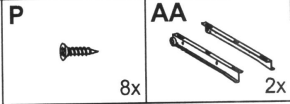

28

